

OFFICE OF THE CHIEF DISTRICT MEDICAL & PUBLIC HEALTH
OFFICER, SUNDARGARH

ଜିଲ୍ଲା ମୁଖ୍ୟ ଚିକିତ୍ସା ଓ ଜନସ୍ୱାସ୍ଥ୍ୟ ଅଧିକାରୀଙ୍କ କାର୍ଯ୍ୟାଳୟ, ସୁନ୍ଦରଗଡ଼

Letter No:-..... /-

Dated:...../...../2023

SECTION-I
DATE & TIME OF TENDER SUBMISSION & FINALISATION

RFP No. CDM & PHO/SNG/2022-23/03

Date: 01/02/2023

DETAILED PROPOSALS ARE INVITED FROM ELIGIBLE BIDDERS FOR SUPPLY OF FORMS/ FORMATS, REGISTER, & FLEX PRINT FOR DIFFERENT PROGRAMME UNDER NATIONAL HEALTH MISSION (NHM)

1	Period Availability of RFP Document	From: 01.02.2023 to 21.02.2023 (Downloadable from website: www.sundergarh.nic.in)
2	Pre-bid Conference (to resolve all the issues, clarification regarding the bid of interested bidder)	Date:-07.02.2023, Time: 11.30 A.M At Office Chamber of CDM & PHO, Sundargarh.
3	Last date for submission of Tender & address	Date:- 21.02.2023 Time: 5.30 P.M Address: CDM & PHO, At/ Po/ Dist.:- Sundargarh, Pin-770001 (Through Speed Post / Registered post / Courier only)
4	Date, time and place of opening of Tender (Technical Bid)	Date: 22.02.2023, Time-11.30 A.M. Place of Tender Opening: O/O CDM &PHO, Sundargarh (Bidders / authorised representative may remain present at the time of opening of tender)
5	Date, time and place of opening of Tender (Financial Bid)	Place of Tender Opening: Only technically qualified bidder will be communicated through registered e-mail id given as per Annexure 1 (RFP)

OFFICE OF THE CHIEF DISTRICT MEDICAL & PUBLIC HEALTH
OFFICER, SUNDARGARH

ଜିଲ୍ଲା ମୁଖ୍ୟ ଚିକିତ୍ସା ଓ ଜନସ୍ୱାସ୍ଥ୍ୟ ଅଧିକାରୀ କାର୍ଯ୍ୟାଳୟ, ସୁନ୍ଦରଗଡ଼

Letter No:-..... / -

Dated:...../...../2023

SECTION-II
TERMS & CONDITION FOR SUPPLY OF FORMS/ FORMATS, REGISTER & FLEX PRINT FOR DIFFERENT PROGRAMME UNDER NATIONAL HEALTH MISSION (NHM)*

- Purchase of Tender Document: Tender document obtained by downloading from the website www.sunderagarh.nic.in.
- The bidders downloading the tender document & required to submit the tender fee through Demand Draft along with their tender bid, failing which the tender bid shall be not be considered for qualifying in technical bid
- The bidder(s) are to submit their tenders in separate sealed covered envelops for technical bid and price bid by superscribing Cover "A" (Technical Bid) & Cover "B" (Price Bid) and both the sealed covers should be put into a third outer Cover, which should be superscribed as "**TENDER FOR THE SUPPLY FORMS/ FORMATS, REGISTER & FLEX PRINT FOR DIFFERENT PROGRAMME UNDER NATIONAL HEALTH MISSION (NHM)***".
- The tender should reach to the under signed as per **Section I** through postal (speed post/registered post) service/ Courier Services only in the address **Office of the Chief District Medical & Public Health officer, Sundargarh, At/Po/Dist-Sundargarh, Odisha Pin-770001.**
- The tenderer or their duly authorized representatives are requested to be present during the opening of the tenders.

TENDER FEE

Tender document fee of Rs.2,000/- (Non refundable) in shape of Demand Draft in favour of ZSS, Non NRHM, Sundargarh from any Nationalised / Scheduled Bank payable at Sundargarh.

EMD MONEY:-

Earnest Money Deposit of Rs. 50,000/- (Rupees fifty thousand only)(Refundable) in shape of Demand Draft in favour of ZSS Non NRHM, Sundargarh from any Nationalized / Scheduled Bank payable at Sundargarh.

- The EMD of successful bidder is liable to be forfeited if the tendered, revokes any terms of the tender within the validity period.
- EMDs given by unsuccessful bidders will be refunded after opening of financial bid.

OFFICE OF THE CHIEF DISTRICT MEDICAL & PUBLIC HEALTH
OFFICER, SUNDARGARH

ଜିଲ୍ଲା ମୁଖ୍ୟ ଚିକିତ୍ସା ଓ ଜନସ୍ୱାସ୍ଥ୍ୟ ଅଧିକାରୀ କ କାର୍ଯ୍ୟାଳୟ, ସୁନ୍ଦରଗଡ଼

Letter No:-..... /

Dated:...../...../2023

- EMD of the successful bidder will be forfeited in case the successful bidder fails to accept/executes the order.
- EMD of successful bidder will be returned after successful completion of terms & condition of supply certificate of all items.
- EMD shall not carry any interest.

ACCEPTANCE OF TENDER AND SUPPLY CONDITIONS:

- The C.D.M & P.H.O, Sundargarh, Odisha reserves the right to reject the tenders or to accept the tenders for the supply of the item tendered without assigning any reason thereof.
- The C.D.M & P.H.O, Sundargarh, Odisha will be at liberty to terminate the contract either wholly or in part without assigning any reasons thereof. The tenderers will not be entitled to any compensation whatsoever for such termination.
- The supply should be completed within 15 days from the date of issue of purchase order unless otherwise specified. If no supply is received even after 15 days or 30 days with liquidated damage from the date of issue of the purchase orders from the C.D.M & P.H.O, Sundargarh, Odisha, such orders will stand cancelled automatically without further notice. Penalties shall also thereafter be applied to the tenderer.
- The approved firm shall also suffer forfeiture of the EMD and Security Deposit.
- If the approved supplier fails to execute the supply within the stipulated time, the C.D.M & P.H.O, Sundargarh, Odisha is empowered to purchase the same items from L₂ or L₃ tenderer if they match the L₁ rate.
- The C.D.M & P.H.O, Sundargarh, Odisha or his authorized representative (s) has the right to inspect the factory of those company who have quoted for the tender, before accepting the rate quoted by them or before releasing any purchase order (s) or at any point of time during the validity period of tender and has also the right to reject the tender or terminate / cancel the orders issued or not to reorder based on the facts brought out during such inspections.

DELIVERY:-

The items will be delivered to the office of the consignee i.e. CHIEF DISTRICT MEDICAL & PUBLIC HEALTH OFFICER, SUNDARGARH/ DIFFERENT HEALTH INSTITUTION IN THE DISTRICT.

LIQUIDATED DAMAGE :-

- The C.D.M & P.H.O, Sundargarh may allow extension for a maximum period of 2 (two) weeks (14 days), after the stipulated date of supply (i.e. 45 days) with a penalty

OFFICE OF THE CHIEF DISTRICT MEDICAL & PUBLIC HEALTH
OFFICER, SUNDARGARH

ଜିଲ୍ଲା ମୁଖ୍ୟ ଚିକିତ୍ସା ଓ ଜନସ୍ୱାସ୍ଥ୍ୟ ଅଧିକାରୀଙ୍କ କାର୍ଯ୍ୟାଳୟ, ସୁନ୍ଦରଗଡ଼

Letter No:-..... /

Dated:...../...../2023

of 0.5% which will be deducted from the purchase order value as "Liquidated Damage", for each week (7 days) upto a maximum 2% on the value of the goods.

- If the supplier fails to complete the supply within the extended period, i.e. 30 days after being allowed by the C.D.M & PHO, no further purchase order will be placed to the firm for the said item and the concerned firm will be blacklisted for three (3) years from the date of issue of letter for the said item.

TERMS OF PAYMENT :

- No advance payments towards cost of material will be made to the tenderer.
- 100% payment will be made after successful supply of the items to the supplying firm.
- No claims shall be made against the C.D.M & P.H.O, Sundargarh in respect of interest on earnest money deposit or security deposit or any delayed payment or any other deposit.
- Payments will be made in shape of PFMS/NEFT after submission of valid invoice/bill.

ELIGIBILITY CRITERIA (to be furnished in technical bid, part of cover A)

1. Tender fee of Rs.2,000/- (non-refundable) should be submitted issued from a Nationalised Bank in favour of ZSS, Non NRHM, Sundargarh payable at Sundargarh.
2. EMD money of Rs.50,000/- in shape of demand draft should be submitted issued from a Nationalised Bank in favour of ZSS, Non NRHM Sundargarh payable at Sundargarh which will be refunded after the validity of Tender.
3. Copy of valid GSTN registration certificate & GST return (Nov-22) should be submitted with the Tender Document.
4. Copy of Income Tax return filling of Firm/agency for Last three Years (2019-20, 2020-21 & 2021-22).
5. Copy of PAN should be submitted with the Tender Document.
6. Copy of Registration certificate of the Firm/Agency with the Tender Document.
7. Relevant Experience Details in supplying the printing material in any Govt. organization & submit minimum 10 nos Photocopies of work orders / contracts

OFFICE OF THE CHIEF DISTRICT MEDICAL & PUBLIC HEALTH
OFFICER, SUNDARGARH

ଜିଲ୍ଲା ମୁଖ୍ୟ ଚିକିତ୍ସା ଓ ଜନସ୍ୱାସ୍ଥ୍ୟ ଅଧିକାରୀଙ୍କ କାର୍ଯ୍ୟାଳୟ, ସୁନ୍ଦରଗଡ଼

Letter No:-..... /-

Dated:...../...../2023

executed in support of the information furnished with the tender during last three Years (2019-20, 2020-21 & 2021-22).

8. Declaration of the organization does not have any legal suit / criminal case pending/blacklisted. (in Affidavit)
9. Undertaking for supply of goods/services as per specification regarding the quality of the products on non judiciary stamp paper minimum worth Rs.50/-.
10. Minimum average Turnover Rs 2,00,00,000.00 (Rupees Two Crore Only) during last three Years (2019-20, 2020-21 & 2021-22). Certificate from Chartered Accountant (CA) have to be submitted.

Other Term & Conditions

1. The firm will have to submit an **undertaking the following-**
 - a) Our organization has not been blacklisted by any Government Organization.
 - b) Our organization does not have any legal suit / criminal case pending against it for violation of GST/VAT/ST/CST Act or any other law.
 - c) The CDM&PHO-Cum-DMD, NHM, Sundargarh will have no liability regarding transportation, loading and unloading of material and all the material ordered for shall be delivered at the designated place in good condition. The defective or damaged material if any will be replaced by our Organization.
 - d) Our organization agrees to abide by all terms & conditions of tender.
2. Liquidated damage will be charged @ 0.5% per week beyond 30 days & up to 60 days subject to maximum 4% total from the date of issue of the purchase order.
Once the delivery period exceeds beyond the extended period with LD, purchase may be considered termination of the contract/Purchase Order.
3. The undersigned/Committee is not bound to accept the lowest tender rate considering the technical and quality aspect.
4. The goods should be supplied to the FOR destination and no charge for freight should be claimed.
5. The rates should be mentioned as rate with GSTN and all other taxes cost in the prescribed Performa separately.
6. The bidder must submit the financial bid & Technical bid as per prescribe format given in the tender, otherwise the bid should be rejected.
7. The tender will not be entertained after due date & time fixed for.

OFFICE OF THE CHIEF DISTRICT MEDICAL & PUBLIC HEALTH
OFFICER, SUNDARGARH

ଜିଲ୍ଲା ମୁଖ୍ୟ ଚିକିତ୍ସା ଓ ଜନସ୍ୱାସ୍ଥ୍ୟ ଅଧିକାରୀ କାର୍ଯ୍ୟାଳୟ, ସୁନ୍ଦରଗଡ଼

Letter No:-..... /

Dated:...../...../2023

8. If any information or documents furnished by the tender are found to be incorrect or misleading at any stage the tender will be rejected.
9. All the documents should be attested by the authorized signatory of the Firm/Agency in **each page with seal**.
10. The approved rate will be valid for one year from the date of finalisation of the tender.
11. All legal disputes are subject to the jurisdiction of **Sundargarh** Courts only.
12. The undersigned have right to cancel/modify/reject/retender at any time during the period of floating of tender and after the tender received or at any point of time with public interest or safeguard of public money.



OFFICE OF THE CHIEF DISTRICT MEDICAL & PUBLIC HEALTH
OFFICER, SUNDARGARH

ଜିଲ୍ଲା ମୁଖ୍ୟ ଚିକିତ୍ସା ଓ ଜନସ୍ୱାସ୍ଥ୍ୟ ଅଧିକାରୀଙ୍କ କାର୍ଯ୍ୟାଳୟ, ସୁନ୍ଦରଗଡ଼

Letter No:-..... /

Dated:...../...../2023

Format for Affidavit certifying that Entity / Promoter(s) / Director(s)/Partners of Entity are not
blacklisted

(On a Stamp Paper of relevant value)

Affidavit

I, M/s. (the name of the
agency with address of the registered office) hereby certify and confirm that we or any of
our promoter(s) / Director(s) are not barred by Department of Health & FW, Govt. of Odisha
/ or any other entity of GoO or blacklisted by any State Government or Central Government
/ Department / Organization in India from participating in Tenders as on the (Date of
Signing of this proposal).

We further confirm that we are aware that, our proposal for the captioned Project would be
liable for rejection in case any material misrepresentation is made or discovered at any stage
of the Bidding Process or thereafter during the agreement period.

Dated thisDay of....., 2022

Authorized Signatory/Signature [In full and initials]:

Name and Title of Signatory:

(Organization Seal)



OFFICE OF THE CHIEF DISTRICT MEDICAL & PUBLIC HEALTH
OFFICER, SUNDARGARH

ଜିଲ୍ଲା ମୁଖ୍ୟ ଚିକିତ୍ସା ଓ ଜନସ୍ୱାସ୍ଥ୍ୟ ଅଧିକାରୀ କା କାର୍ଯ୍ୟାଳୟ, ସୁନ୍ଦରଗଡ଼

Letter No:-..... /

Dated:...../...../2023

Annexure I

(To be furnished in Technical Bid, part of Cover A)

1	Name of the Organization	
2	Address of the Organization	
3	Name of authorized signatory (in capital letters)	
4	Telephone/Mobile number & e-mail Id of authorized signatory / organization	
5	GSTIN Registration No. & GST return (Nov- 22)	(Photo copy to be attached)
6	PAN No.	(Photo copy to be attached)
7	Draft number and date of the Tender Document Cost of Rs. 2,000/- (Non- Refundable)	(Original Draft to be submitted)
8	Draft No. & date of EMD of Rs 50,000/-	(Original Draft to be submitted)
9	Copy of Income tax return (last three financial years i.e 2019-20, 2020-21 & 2021-22).	(Photo copy to be attached)
10	Certificate of Turnover from CA	Copy to be attached
11	Undertaking for supply of goods/services as per specification	Original undertaking in non judiciary stamp paper minimum worth Rs.50/-.
12	Declaration of the organization does not have any legal suit / criminal case pending. (in Affidavit)	(Original copy of Undertaking)
13	The bidder should have experience of satisfactory supply of tendered item during the last 3 years (put together) considered from the date of publication. (10 nos)	(Photo copy experience to be attached.)
14	Whether all documents are submitted and signed by the authorized signatory of the organization in each page with seal (Yes/ No)	

DECLARATION

I / we hereby certify that the terms and conditions, specification etc. given with the tender notice have been read carefully and acceptable to me/us and that the information furnished above is correct to the best of my /our knowledge. I / we understand that in case of any deviation in the above statement / furnishing of forged documents etc. at any stage, our Firm/Agency will be blacklisted and will not have any dealing with your organization in future.

(Signature and seal of the authorized signatory)

Place :

Date :

Technical Specification (Part of Cover A)

SI No	NAME OF THE ITEM	SPECIFICATION	Unit of measurement
1	Poster for GKS/WKS Swasthya Kantha	Size - 44 cm X 56 cm, Process Multi colour (Four colour), Paper- 130 GSM Art Paper, Fixing with adhesive double side Gum tape in the back side of poster.	Per Piece Rate
2	Calendar	Size - 75 cm X 50 cm, Process Multi colour (Four colour), Paper- 170 GSM Art Paper, Fixing with adhesive double side Gum tape on the back side of the Calendar.	Per Piece Rate
3	Poster (Type 1)	Size - 44 cm X 56 cm, Paper - 170 GSM Art Paper, Process - Multi Colour Printing.	Per Piece Rate
4	Poster (Type 2)	Size - 44 cm X 56 cm, Paper - 130 GSM Art Paper, Process - Multi Colour Printing.	Per Piece Rate
5	Poster (Type 2)	Size - 44 cm X 56 cm, Paper - 170 GSM Art Paper, Process - Multi Colour Printing. Fixing with adhesive double side Gum tape in the back side of poster.	Per Piece Rate
6	Poster (Type 3)	Size - 44 cm X 56 cm, Paper - 130 GSM Art Paper, Process - Multi Colour Printing. Fixing with adhesive double side Gum tape in the back side of poster.	Per Piece Rate
7	Poster (Type 4)	Size: 59CMX45.5CM Process: Multi Colour (4 Colour 4 Type) Paper 130 gsm Art Paper, Back Side Adhesive.	Per Piece Rate
8	Poster (Type 5)	Size: 59CMX45.5CM Process: Multi Colour (4 Colour 2 Type) Paper 130gsm Art Paper, Back Side Adhesive.	Per Piece Rate
9	Poster (Type 6)	Size: 44CMX56CM Process: SingleColour, Paper 130 gsm Art Paper, Back Side Adhesive.	Per Piece Rate
10	Leaflet (type 7)	Size - 22 cm X 28 cm, Paper - 130 GSM Art Paper, Process - Multi Colour, Single side Print.	Per Piece Rate
11	Leaflet (type 2)	Size - 22 cm X 28 cm, Paper - 130 GSM Art Paper, Process - Multi Colour, Both Side printing.	Per Piece Rate
12	Leaflet (type 3)	Size - 22 cm X 28 cm, Paper - 90 GSM Art Paper, Process - Multi Colour, Single side Print.	Per Piece Rate
13	Leaflet (type 4)	Size - 22 cm X 28 cm, Paper - 90 GSM Art Paper, Process - Multi Colour, Both Side printing	Per Piece Rate
14	Leaflet (type 5)	Size - 15.5 cm X 21.8 cm, Paper - 130 GSM Art Paper, Process - Multi Colour, Single side Print.	Per Piece Rate
15	Leaflet (type 6)	Size - 15.5 cm X 21.8 cm, Paper - 130 GSM Art Paper, Process - Multi Colour, Both Side Printing	Per Piece Rate
16	Leaflet (type 7)	Size - 15.5 cm X 21.8 cm, Paper - 90 GSM Art Paper, Process - Multi Colour, Single Side Print.	Per Piece Rate
17	Leaflet (type 8)	Size - 15.5 cm X 21.8 cm, Paper - 90 GSM Art Paper, Process - Multi Colour, Both Side printing	Per Piece Rate
18	Folder (Type 1)	Open Size - 44 cm X 28 cm, Close Size - 22 cm X 28 cm, Paper - 220 GSM Art Paper, Process - Multi colour, Single fold, 4 pages, Both side printing	Per Piece Rate
19	Folder (Type 2)	Open Size - 44 cm X 28 cm, Close Size - 22 cm X 28 cm, Paper - 170 GSM Art Paper, Process - Multi colour, Single fold, 4 pages, Both side printing	Per Piece Rate
20	Folder (Type 3)	Open Size - 36 cm X 24.5 cm, Close Size - 18 cm X 24.5 cm, Paper - 220 GSM Art Paper, Process - Multi colour, Single fold, 4 pages, Both side printing	Per Piece Rate

21	Folder (Type 4)	Open Size – 36 cm X 24.5 cm, Close Size - 18 cm X 24.5 cm, Paper – 170 GSM Art Paper, Process - Multi colour, Single fold, 4 pages, Both side printing	Per Piece Rate
22	Folder (Type 5)	Open Size – 28 cm X 14 cm, Close Size - 14 cm X 14 cm, Paper – 220 GSM Art Paper, Process - Multi colour, Single fold, 4 pages, Both side printing	Per Piece Rate
23	Folder (Type 6)	Open Size – 28 cm X 14 cm, Close Size - 14 cm X 14 cm, Paper – 170 GSM Art Paper, Process - Multi colour, Single fold, 4 pages, Both side printing	Per Piece Rate
24	Handouts (Type 1)	Job Type- Folder design, colour, front + back, CMYK (4 Colour), Orientation- Landscape, Print Process- Offset, Paper Quality- 100 GSM, Final Print Size- 24.75" X 11.69" inches (Custom size) Post Processes: Creasing, Perforation.	Per Piece Rate
25	Handouts (Type 2)	Size-7 ½ x16 ¾ Inches Paper: 300 gsm Art paper Multi Colour back to back. Binding : 2 fold,Machine Ceasing.	Per Piece Rate
26	Handouts (Type 3)	Size-7 ½ x16 ¾ Inches Paper: 300 gsm Art paper Multi Colour back to back. Binding :3fold,Machine Ceasing	Per Piece Rate
27	Handouts (Type 4)	Size-1/4 Demi Multi Colour Both Side Printing 2 fold paper Machine Creasing Paper : 170 gsm Map Litho.	Per Piece Rate
28	Handouts (Type 5)	Size-1/6 Demi Multi Colour Both Side Printing 2 fold paper Machine Creasing Paper : 170 gsm Map Litho.	Per Piece Rate
29	Handouts (Type 6)	Size-1/4 Demi Multi Colour Both Side Printing 3 fold paper Machine Creasing Paper :300 gsm Map Litho.	Per Piece Rate
30	Handouts (Type 7)	Size-1/6 Demi Multi Colour Both Side Printing 3 fold paper Machine Creasing Paper : 300 gsm Map Litho.	Per Piece Rate
31	Flipcharts	Job Type- Flipchart, colour, front + back, CMYK (4 Colour) Orientation- Portrait, wall calendar style, Refer to image, Print process- Offset, Paper type- 170gsm – 220gsm, uncoated, Final print size- 16.54" X 23.39" inches (A2) Post Process: Spiral Binding, Cardboard on the back, Metal eye (rivet) for hanging it from a nail, Front & Back mirror printing: 1-3,2-5,4-7,6-9,8-11,10-13.....20 blank	Per Piece Rate
32	Docket	Job Type- Colour, Front + Back, CMYK (4 Colour), Pre-Press – Make a screen, Landscape –Portrait, Printing Process- Offset Printing/ Screen Print, Paper Type- 300 GS Matt. Final Print Size – 9 inches X 12 inches, A4 folder, White. Post Process- Pasting of A4 sheet- if you choose offset, Creasing – If you choose offset	Per Piece Rate
33	Hand Bill	Job type- Colour, Front + Back, CMKY(4 Colour) Orientation: Portrait, Printing Process -Offset Printing, Paper type 130 GSM, Uncoated, Print size 8.27" X 11.69"	Per Piece Rate
34	Patient Treatment Card Book let	Cover Page Open Size - 28cm X 22cm, Close Size – 14cm X 22cm, Printing Process - Multi colour with both side printing, Paper quality - 220 GSM Art Paper. Single Fold 4 pages. Inner Page Open Size - 28cm X 22cm, Close Size – 14cm X 22cm, Printing Process -black & white both side printing, Paper quality - 80 GSM paper single fold. Total Inner page five pages of open size. Post Process - to be stapled in the middle of the booklet.	Rate per Booklet
35	Patient Case Card	1/4 Demy single colour, Paper 250gsm with both side printing.	Rate per card
36	Printing Forms (Type 1)	Printing of forms in A 4 Paper, Single SidePrinting, 60-70 GSM	Rate Per Piece

37	Printing Forms (Type 2)	Printing of forms in A 4 Paper, Double Side Printing, 60-70 GSM	Rate Per Piece
38	Printing Forms (Type 3)	Printing of forms in A 3 Paper, Single Side Printing, 60-70 GSM	Rate Per Piece
39	Printing Forms (Type 4)	Printing of forms in A 3 Paper, Double Side Printing, 60-70 GSM	Rate Per Piece
40	Printing Forms (Type 5)	Printing of forms in A 2 Paper, Single Side Printing, 60-70 GSM	Rate Per Piece
41	Printing Forms (Type 6)	Printing of forms in A 2 Paper, Double Side Printing, 60-70 GSM	Rate Per Piece
42	Printing Forms (Type 7)	Printing of forms in Legal Paper, Single Side Printing, 60-70 GSM	Rate Per Piece
43	Printing Forms (Type 8)	Printing of form`s in Legal Paper, Double Side Printing, 60-70 GSM.	Rate Per Piece
44	Printing Forms (Type 9)	Printing of forms in Legal Paper, Single Side Printing, 90 GSM	Rate Per Piece
45	Printing Forms (Type 10)	Printing of forms in Legal Paper, Double Side Printing, 90 GSM	Rate Per Piece
46	Printing Forms (Type 11)	Printing of forms in A 4 Paper, Single Side Printing, 90 GSM	Rate Per Piece
47	Printing Forms (Type 12)	Printing of forms in A Paper, Single Side Printing, 90 GSM	Rate Per Piece
48	HBNC Format	Unit: Booklet Size: 1/4 Demy Total No. Pages: 12 Paper (All Pages): 80gsm Maplitho Paper Brightness: 77 (Minimum) Printing (All Pages): Both Side Black Binding: Centre Stitching With Perforation Of Last Page (2 Nos. Of Perforation In The Last Page)	Rate per Booklet
49	Monthly Meeting Register	Unit: Register Size: 20cm x 30cm Inner Pges: 84 Cover Pages: 4 Paper (Inner) : 70gsm Paper (Cover): 70gsm Maplitho To Be Pasted On The Hard Board Binding After Printing (Inner): -Both Side Black Offset Printing. Printing (Cover): Multi Colour Offset Printing of Front And Back . Binding: Zoo Stitching With Thick Hard Board & Cloth Binding At Left Side Of The Register	Rate Per Register
50	Grade Card	Unit: Card Size: 1/4 Demy Printing: Single Side Multi Colour Offset Printing Paper: 160gsm Drawing Sheet.	Rate per card
51	Printing of various Incentive Voucher Book: 200 GSM thin board Cover page with binding	Unit: Booklet Size: A4 Total No. Of Pages: up to 100 pages Paper (Inner): 80 GSM Printing: Black & White Single Side Printing With Perforation.	Rate per page
52	Printing of various Incentive Voucher Book: 200 GSM thin board Cover page with binding	Unit: Booklet Size: A4 Total No. Of Pages: more than 100 pages Paper (Inner): 80 GSM Printing: Black & White Single Side Printing With Perforation.	Rate per page

53	Printing of Various Formats: 200 GSM thin board Cover page with binding	Unit: Booklet Size:A4 Total No. Of Pages: up to 30 pages Paper (Inner):80 GSM Printing: Black & White both Side Printing	Rate per booklet
54	Printing of Various Formats: 200 GSM thin board Cover page with binding	Unit: Booklet Size:A4 Total No. Of Pages: up to 30 pages Paper (Inner):80 GSM Printing: multicolour both Side Printing	Rate per booklet
55	Printing of various Training Modules: 220 GSM laminated Cover page (multi-Colour) with gum binding.	Total Pages: up to 100 pages Paper Size: A4 Paper: 80GSM Printing: Both Side Black & White: All Pages	Rate per page
56	Printing of various Training Modules: 220 GSM laminated Cover page (multi-Colour) with gum binding.	Total Pages: above 100 pages Paper Size: A4 Paper: 80GSM Printing: Both Side Black & White: All Pages	Rate per page
57	Printing of various Training Modules: 220 GSM laminated Cover page (multi-Colour) with gum binding.	Total Pages: up to 100 pages Paper Size: A4 Paper: 80GSM Printing: Both Side Multi-colour: All Pages	Rate per page
58	Printing of various Training Modules: 220 GSM laminated Cover page (multi-Colour) with gum binding.	Total Pages: above 100 pages Paper Size: A4 Paper: 80GSM Printing: Both Side Multi-colour: All Pages	Rate per page
59	Printing of St. Records& case card	Black & white Printing booklet: Paper Size- Open: 42cm X 28 cm, Close: 21cm X 28 cm, 2 fold. Total pages – Four pages of Open size with both side printing. Post Process – Stapling as booklet of 8 pages as close size. Paper Quality – 60 or 70 GSM	Rate Per Booklet
60	Booklet Type 1	B/W printing of Binding Booklet - 100 pages (50+50) Original & Duplicate, Paper size-A 4, Paper Quality – 60 to 70 GSM. Post Process:- Binding with cardboard in last page & binding with 220 GSM paper on the top cover of the booklet with tearing mark at the top.	Rate Per Booklet
61	Booklet Type 2	Size-7 ½ x16 ¼ Inches Paper: 300 gsm Art paper Multi Colour back to back. Binding : 2 fold, Machine Ceasing.	Rate Per Booklet
62	Register 1	B/W Both side printing & Binding - 100 pages, Paper size-A 3, Paper Quality – 60 to 70 GSM. Post Process:- Binding with cardboard in last page & binding with 220 GSM paper on the top cover & last page of the Register.	Rate per Register
63	Register 2	B/W Both side printing & Binding - 200 pages, Paper size-A 3, Paper Quality – 60 to 70 GSM. Post Process:- Binding with cardboard in last page & binding with 220 GSM paper on the top cover & last page of the Register.	Rate per Register
64	Rolling Register 1	120 pages, Paper Size –FS (34.5 x 21.5) cm, Paper Quality – 60 to 70 GSM. Post Process:- Binding with card board on front & back cover	Rate per Register

		of register.	
65	Rolling Register 2	240 pages, Paper Size – FS (34.5 x 21.5) cm, Paper Quality – 60 to 70 GSM. Post Process:- Binding with card board on front & back cover of register.	Rate per Register
66	Register (Type 1)	100 Pages register with single side printing, Paper Size- A 4 (21 X 29.7) cm, Paper Quality- 60 – 70 GSM. Post Process:- Binding with Thick paper on front & card board on back cover of register.	
67	Register (Type 2)	100 Pages register with single side printing, Paper Size- FS (21.5 X 34.5) cm, Paper Quality- 60 – 70 GSM. Post Process:- Binding with Thick paper on front & card board on back cover of register.	Rate per Register
68	Register (Type 3)	100 Pages register with single side printing, Paper Size- (28.5 x 41.5) cm, Paper Quality- 60 – 70 GSM. Post Process:- Binding with Thick paper on front & card board on back cover of register.	Rate per Register
69	Register (Type 4)	200 Pages register with single side printing, Paper Size- A 4 (21 X 29.7) cm , Paper Quality- 60 – 70 GSM. Post Process:- Binding with Thick paper on front & card board on back cover of register.	Rate per Register
70	Register (Type 5)	200 Pages register with single side printing, Paper Size- FS (21.5 X 34.5) cm , Paper Quality- 60 – 70 GSM. Post Process:- Binding with Thick paper on front & card board on back cover of register.	Rate per Register
71	Register (Type 6)	200 Pages register with single side printing, Paper Size- (28.5 x 41.5) cm, Paper Quality- 60 – 70 GSM. Post Process:- Binding with Thick paper on front & card board on back cover of register.	Rate per Register
72	Register (Type 7)	300 Pages Register, Paper size- A 3, Single side print Paper Quality - 60-70 GSM, Post Process: Binding with Cardboard on the front &back side of Register.	Rate per Register
73	Register (Type 8)	300 Pages Register, Paper size- A 3, both side printing, Paper Quality - 60-70 GSM, Post Process: Binding with Cardboard on the front &back side of Register.	Rate per Register
74	Incentive Voucher book	50 pages voucher book with single side Printing, Paper quality - 80 GSM, Paper size - (10.5 X 29.7) cm. Post Process:- Binding with 220 GSM paper on front & back cover & Tearing mark in the voucher book.	Rate per voucher book
75	Envelope type 1	Printing of Yellow colour Envelope for X-ray film, free size for 10 inches X 12 inches X-ray film, Paper quality-80 GSM .	Rate per Envelope
76	Envelope type 2	Printing of Yellow colour Envelope for X-ray film, free size for 12 inches X 15 inches X-ray film, Paper quality-80 GSM.	Rate per Envelope
77	Sticker Type 1	Sticker size - 14 cm X 22, Paper quality - Sticker Paper with multi colour printing.	Rate per Sticker
78	Sticker Type 2	Sticker size - 28 cm X 44, Paper quality - Sticker Paper with multi colour printing.	Rate per Sticker
79	E-Auto Sticker type 1	Size:9"x9" Logo (NHM,DMF & Odisha Govt) Stickers for E-Auto Front ,Vinyl print with backside Adhesive .	Rate Per Sq. Ft
80	E-Auto Sticker type 2	Size:10"x20" E-Auto Both Side Branding , (Odia & English) ,Vinyl print with backside Adhesive.	Rate Per Sq. Ft
81	Standee Type 1	Aluminium Framed standee including multi colour flex printed banner (Folding Type)	Rate per standee
82	Standee Type 2	Size-5'x3',3'x2' Flex print 250gsm with iron frame angel of (1"x1") -printing & mounting of banner.	Rate per sqft
83	Standee Rolling Type	Size: 6'x3' Cardboard or rigid plastic such as Coro plast, paper foam board ,styrene capped foam board or expanded foam PVC.	Rate per sqft

84	Invitation Card	Size - 14 cm X 22 cm, Paper quality – 80 GSM Map litho, Process- Both side multicolour printing.	Rate per Card
85	Certificate	Size – 5" X 9.7", Paper quality – 250 GSM Art Paper, Process- multicolour single side printing.	Rate per certificate
86	Pushing Card	Size: 13.5 cm X 9 cm, Process: Multi colour, Paper: 220 GSM art paper, Printing : Both Side	Per Card
87	Identity Card/ Grade Card	Unit : Card Size : ¼ Diemy, Paper : 220 GSM Drawing sheet Printing : Single side multi colour offset printing	Per Card
88	Printing of Flex Banner	Job Type – Multi colour printing, CMYK (4 Colour) Good Quality Flex (minimum 240 GSM thickness) to be used, Post Process - 4 punch holes at each corner.	Rate Per Sq. Ft
89	Flex print	As per requirement, Multi colour printing(250gsm)	Rate Per Sq. Ft
		250 gsm fitting with Iron Pipe In existing hoarding located at different place of the District.	Rate Per Sq. Ft
90	Change of Flex in Hoardings	Good quality flex with Multi colour printing and fitting on the strategic departmental Hoardings at DHH, SDH& Block CHCs.	Rate per Sq. Ft. for Hoarding flex change
91	Exhibit/Standee	Multi colour flex printing and fixing on the 1" iron square bar frame with inside support and fitting stand at the back side of the frame, Frame Size - 1 inch X 1 inch of Iron gauze bar of 20 gauges.	Rate Per Sq. Ft
92	Vehicle Decoration	Decoration of TATA ACE /MAGIC Vehicle on various campaign programmes. The vehicle is to be designed & fitting with good quality flex framed with iron square bar of size 1 inch X 1 inch.	Rate Per vehicle
93	Wall Painting	Multi Colour Painting after double coat good quality White Enamel paint over wall there after multi colour design Art Works & Writing Works, Materials to be used:- Branded Paint from Asian paint-Apex (water proof)	Rate Per Sq. Ft
94	Printing & Mounting of IEC materials (Sun Board) Type 1	Materials to be used - 3 mm Thickness Sun Board. Printing Process – Eco Solvent Vinyl Print multi colour & mounting with steel stud in 4 corners at institutions. (Including fitting charges)	Rate Per Sq. Ft
95	Printing & Mounting of IEC materials (Sun Board) Type 2	Materials to be used - 6mm Thickness Sun Board. Printing Process – Eco Solvent Vinyl Printing & mounting with steel stud in 4 corners at institutions. (Including fitting charges)	Rate Per Sq. Ft
96	Retro Signage for RI & UHND/VHND points	Board Size:- 1.5 Ft Height x 1 ft Width Fitting & Fixing up signage in Retro -Reflective Sheet with 2 MM tin sheet with UV laminated	Rate Per Sq. Ft
97	Branding/ Mounting of IEC materials	Materials Specification for Branding Work (Acrylic Signage Display- Sandwich Model), Base Sheet:- Imported Acrylic Sheet - 4mm thickness. Topping Sheet:- Imported Acrylic Sheet - 3mm thickness Fitting type:- Wall mount with stainless stud at 4 corners, Printing Process:- Multi colour printing by using imported colour tone. Lamination:- Matte type lamination, Pasting:- Flash cut and should be orderly pressing without air bubble inside.	Rate Per Sq. Ft.
98	Cloth Banner Type 1	Size – 48" X 16" , Yellow Colour with blue print letter	Rate per unit
99	Cloth Banner Type 2	Size – 100" X 32" , Yellow Colour with blue print letter	Rate per unit

100	Branding of Vehicles	Eco solvent printing on Vinyl substrate with snickering provision for sharper image quality. Multicolour Stickers to be made as per sample.	Rate Per Sq. Ft.
101	IPU Sign Board Type 1	Size-6'x4' Front Sign Board-Sunboard with vinyl print thickness 3mm (sun board)	Rate Per Sq. Ft.
102	IPU Sign Board Type 2	Size-3'x6' Facility display board-sunboard with vinyl print thickness 3mm (sun board)	Rate Per Sq. Ft.
103	IPU Sign Board Type 3	Size-6'x4' Wall poster for paediatric room- sunboard with vinyl print thickness 3mm (sun board)	Rate Per Sq. Ft.
104	IPU Sign Board Type 4	Size-6'x4' Wall poster for general therapeutic room – sunboard with vinyl print thickness 3mm (sun board)	Rate Per Sq. Ft.
105	IPU Sign Board Type 5	Size-18"x8" Room identification Name Plates-Vinyl print with back side Adhesive.	Rate Per Sq. Ft.
106	Signage	Materials to be used: Imported Acrylic Sheet, (Sandwich Model) , Material Quality : 4 mm Thickness. Process: Multi colour snickering on acrylic sheet by using imported colour tone. Post Process:- Fitting by Wall mount with stainless stud at 4 corners/ fitting by hanging stand over / side of wall.	Rate Per Sq. Ft
106	Digital Display Board	LED type display board, display in Red colour letter, Led composition-1024 led/ sq ft, Led Block Resolution Rate- 32 X 32 led/ sq ft, Cabinet material- Metal Steel in black or gray colour. Effects: - Static/Scrolling/ Flashing, Character Style:- Normal, Bold, Italic compressed. Multiple speed setting, multiple language, Date & Time (Optional) Memory Capacity 5000 character. Availability of Editing Facility. Operating Soft Ware:- Updated version. Supported OS XP – 2000, WINDO – 7/8, Clearly visible in day & night, Scan Rate:- ¼ latest technology, Colour temperature:- 6500 K – 9500 K, Frequency:- 50 Hz, Input voltage:- AC 110/220 V +/- 10 %	Rate Per Sq. Ft
108	Tin Plate 1	0.20 mm thick as per I.S 1993/93, 5 times pre-printing Chemical treatment , 4 times multi coloured printing, Transparent coating and heat treatment at 200 degree C, Punching Hole of Diameters not more than 2mm at each corner of the sheet (All total 06 nos of punching hole) Size:90CM X 60CM , Multi Colour.	Rate per Piece
109	Tin Plate 2	0.20 mm thick as per I.S 1993/93, 5 times pre-printing Chemical treatment , 4 times multi coloured printing, Transparent coating and heat treatment at 200 degree C,Punching Hole of Diameters not more than 2mm at each corner of the sheet (All total 06 nos of punching hole) Size:120CM X 90CM , Multi Colour.	Rate per Piece
110	Glow Sign Board	Material - Star back lit Flex, Multi-colour printing & fixing on the Iron frame Box - 18 gauge GI sheet, Back Lid print including electrical quality lighting	Rate per Sq ft
111	Vinyl print(Poster)	Size 3' x2', 4x3'Multi Colour Printing with back side adhesive	Rate per Sq ft
112	Erection of new Hoarding	Size of hoarding:8'x16',15'x30',12'x15'. <u>Specification</u> Quality: Angle/Joist Frame Used should be of Good Quality. Joist- 5"x2.5" Angle-3"x3" Angle 2"x2"	Rate per Sq ft.

		<ul style="list-style-type: none"> • Base of each pole of the hoarding should be buried at least 2 ½ feet and cement concreted all around the buried part as well as 1 Ft above the ground. • Frame should be of Iron Angle • Fabric / cloth should be of good quality with digital multicoloured printing. • Fabric / cloth should be fixed by iron pipes and GI Wires. • Structure of the hoarding will be at a height of 5 feet from the ground level so as to be clearly visible from distance. • Care must be taken not to selection behind the tree/ any other structure obstructing behind the view. • The hoarding should be so installed (preferably at right angle to the direction of passing road/entrance to the campus area) that it easily catches the vision of the passers by people. 	
113	Welcome Board of MAS	<p>Size of hoarding :- 2ft & 1 Ft</p> <p><u>Specification</u> printed or pasted 1 mm thick tin plated or Tin plate with Fabric pasting or ACP with Vinyl Pasting 2 Legs 2"x 2" L angle MS Rod of Ht 4.5 Ft</p>	Rate per Sq ft
114	Mini Hoarding	<p>Size of hoarding :- 6ft & 3 Ft</p> <p><u>Specification</u> 18 Gauge printed or painted tin plated or Tin plate with Fabric pasting or ACP with Vinyl Pasting 10 Ft L iron angle (2" L MS Iron Angle) 2ft Inside Ground & Cement Concrete Ground to Top :- 8.0 Ft Length 6 Ft Width & 3 Ft Long Mid Joist Bar 3 ft Quality: Joist- 5"x2.5" Angle-3"x3" Angle 2"x2"</p>	Rate per Sq ft
115	Installation of Retro-Hoarding	Providing, Fixing, <i>fitting</i> retro-reflective sheet on 4 mm aluminium sheet/ ACP (0.25 +3.50+0.25-pdvc coated) OEM Matched component & UV laminated	Rate per Sq ft
116	Printing of Fabric Banner	Job Type – Multi colour printing, CMYK (4 Colour) Good Quality Flex (minimum 240 GSM thickness) to be used, Post Process - 4 punch holes at each corner	Rate per Sq ft
117	Canopy Type 1	Size:5'x5'x7' Fabric Cotton inner and side of the kiosk/Canopy should be displayed with different message. Process: Steel frame with Good quality flex(minimum 249 GSM thickness) to be used	Rate Per Sq ft
118	Canopy Type 2	Size:5'x5'x7' Fabric Cotton inner and side of the kiosk/Canopy should be displayed with different message. Process: Iron frame with Good quality flex(minimum 249 GSM thickness) to be used	Rate Per Sq ft
119	Canopy Type 3	Size:5'x5'x7' Flex inner and side of the kiosk/Canopy should be displayed with different message. Process: Steel frame with Good quality flex(minimum 249 GSM thickness) to be used	Rate Per Sq ft
120	Canopy Type 4	Size:5'x5'x7' Flex inner and side of the kiosk/Canopy should be displayed with different message. Process: Iron frame with Good quality flex(minimum 249 GSM thickness) to be used	Rate Per Sq ft
121	IEC Calendar	Size of each sheet of calendar 91CM x 58.5 CM ,No of sheets in each calendar:10 sheets, Colour: Multi colour, Binding: Each sheet both side lamination, Tip wire with hanger, calendar is packed with	Rate per Calendar

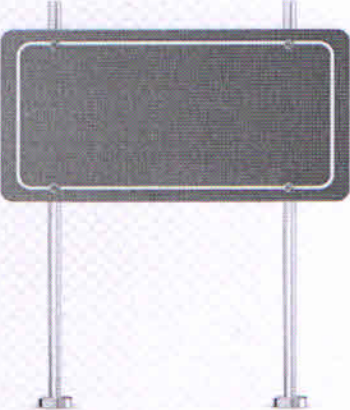
		a strong polythene bag/envelope size 24"x37"	
122	Exhibits	Size: 6'x4',4'x2',3'x2' Process: Sun board, Eco solvent print& bidding	Per sq ft.
123	Display Board	Materials: 3mm Thickness Sun Board. Printing Process – Eco Solvent Vinyl Print multi colour. Size: 6'x4',4'x2',3'x2'	Per sq ft
124	Installation of Retro-Hoarding	<p>Preferable Board Size: 4ft height x 3ft Width</p> <p>Providing, fitting, fixing up informative boards using upper high efficiency full cube Retro-reflective sheeting of white colour bonded on to 4mm aluminum sheet/ACP(0.25+3.50+0.25-pd/vf coated) over which alphabet sand numerical are printed using of matched component ink sand UV laminated with OEM approved over laminates (covers 3 years warranty from the date of manufacturing on colour fading, peel off) The board shall be provided with frame made out of 20² grade stainless pipes shall be mounted on two vertical posts made out of 50mm NB stainless pipe as have been installed including concreting/reveling reinforcement etc. The height of this post should be 10ft in which 1.5ft under the ground, rest will visible above of the ground.</p> <p>Fixing of the board including cost of the materials, conveyance ,labor, transportation etc. required for the work.</p>  <p>The Size can be adjusted as per the provisioned price. As these boards are light sensitive with high reflective index for better night visibility. These boards should be fixed preferably on the road sides so that it will be visible at night in traffic light.</p>	Per sq ft

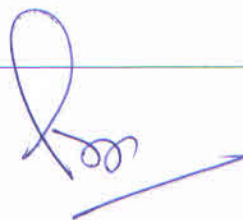

<p>125</p>	<p>Permanent (Iron Frame) Hoardings near religious places, along highways, market places and other strategic</p>	<p>Preferable Size of hoarding level is- 15ft x 12ft (However, there is flexibility to decide it by concerned City/MC/District level keeping in view the provision of space and visibility.)</p> <ul style="list-style-type: none"> ▪ Quality: Angle/Joist frame used should be of good quality MS with epoxy painting. <ul style="list-style-type: none"> ○ Joist- 5"X 2.5" ○ Angle- 3"X 3" ○ Angle- 2"X 2" <p>Base of each pole of the Hording should be buried at least 2½ feet M-15 grade cement* concrete, reinforcement and cement concreted all around the buried part as well as 1 foot above the ground.</p> <ul style="list-style-type: none"> ▪ Frame should be of Iron Angle ▪ Fabric/cloth matter should be of good quality with digital multi colored printing ▪ Fabric/cloth should be fixed by iron pipe sand and GI wires ▪ Structure of the hoarding will be at least at a height of 5 feet from the ground level so as to be clearly ▪ Visible from a distance. ▪ Care must be taken not to select locations behind a tree/ any other structure obstructing the view. ▪ The hoardings should be so installed (preferably at right angle to the direction of passing road/entrance) so that it easily catches the vision of the passers by/people. 	<p>Per sq ft</p>
------------	---	---	------------------

126	<p>Change of matter(Fabric) in existing Large hoardings</p>	<p>The existing dynamic hoardings should be mounted with new content using fabric media instead of flex banner (use of flex banner is restricted under ban of polythene/plastic act).The theme should be decided on local specific issues and accordingly the content must be designed, printed and mounted utilizing</p>	Per sq ft
-----	--	---	-----------

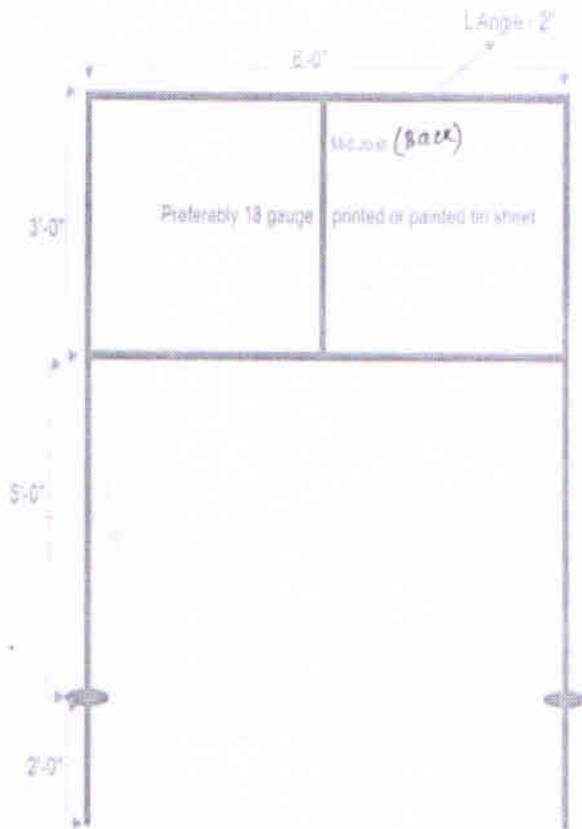
27	<p>Mini Hoardings Type 1</p>	<p>Option1: 6ftX3ft Display area: 6ftX3ft Display Material: Preferably 18 gauge printed or painted Tin Plate or Tinplate with fabric pasting or iron framed with fabric or ACP with vinyl pasting</p> <p>Total Height from the inside the ground: 10ft Length Iron angle(2" LMS Iron Angle should be used) Base(Inside Ground): 2.0 ft inside cement concrete Above Ground(Ground to Top):8.0ft Length: 6ft L Iron angle(2" LMS Iron Angle should be used) Mid Joist Bar to support display material: 3ft L MS Iron angle (2" L MS Iron Angle should be used) In case of MS Iron angles the water proof Painting preferably epoxy paining should be done.</p> <p>Option-1 : Suggested Mini Hoarding Structure Specification (6' x 3')</p> 	Per sq ft
----	-------------------------------------	---	-----------

Mini Hoardings
Type 2

Option 2: 4ft X 3ft

Display area: 4ft X 3ft Display Material:

Preferably 18 gauge printed or painted Tin Plate or Tinplate with fabric pasting or fabric only

Total Height from the inside the ground: 10ft LMS Iron angle (2" L Iron Angle should be used)

- Base (Inside Ground): 2.0ft inside cement concrete
- Above Ground (Ground to Top): 8.0ft

Length:

4ft LMS Iron angle (2" L Iron Angle should be used)

In case of MS Iron angles the water proof painting preferably epoxy painting should be done.

Per sq ft

Option-2 : Suggested Mini Hoarding Structure Specification (4' x 3')

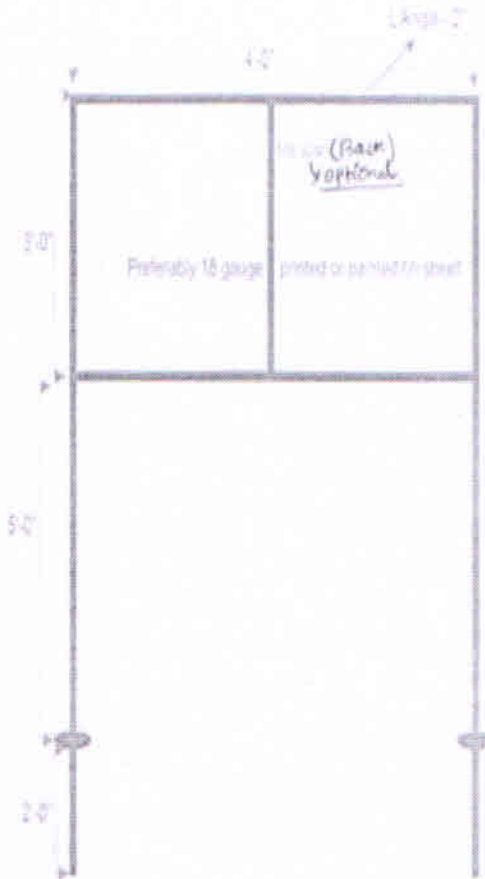

Handwritten signature

→

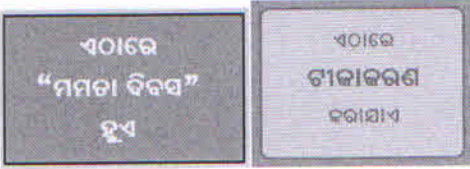
129	<p>Retro Signage for UHND & RI Points</p>	<p>Preferable Board Size: 1.5ft height x 1ft Width Providing, fitting, fixing up signage using upper high efficiency full cube Retro-reflective sheeting of white colour bonded on to 2 mm tin sheet over which alphabets and numerical are reprinted using goematched component inks and UV laminated with oem approved over laminates.</p>  <p>It should be displayed outside the UHND/RI Sites to attract public attention with proper visibility in both day and night</p>	PerSq.ft.
130	<p>Wall paintings for health education @1 per WKS</p>	<p>The color to be used for panting should be water proof as per the specification mentioned below; Size: preferably 6ftX3ft or 5ftX4ft or any other size as per the availability of the space in the local areas to be decided by the local authority. Shape: Preferably rectangular Type: Wall Painting, Hand made Colour: Multi colour Finish: Matt finish, Gloss, Smooth & Polished Medium: Oil Material: Use best quality Paints That increases the sharpness of color and remain waterproof & long lasting (Acrylic Emulsion , Vinyl, Canvas) Position: Outdoor Use Stencils to make uniform designs</p> <p>The wall paintings should be done by hiring local artists or agencies following proper procurement procedure preferably fixing the rate per square feet unit cost. The message for the wall painting should be decided by the local authority keeping in view the prevalence of the health issue of their respective areas. The wall painting should be done inside communities/slums at better public visible places.</p>	PerSq.ft.

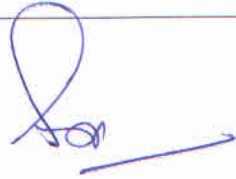

131

Welcome Board of MAS@1PerMAS)

Suggestive Specifications:
MAS Welcome Board: 2ftX1ft size Printed 1mm thick in sheet or 1mm thick Tin sheet pasted with Matt laminated printed vinyl for longevity with frame of 1"x1" L angle MS rod fixed with 2 legs 2"x2" L angle MS rod of height 4.5ft out of which 1ft to be inside ground with concrete reinforcements. All fixing of the display board should be done by applying welding for strength and longevity. As drawing of the welcome board is given below for reference.

MAS
 Welcome Board (2ft X 1ft)
 Printed T in Sheet

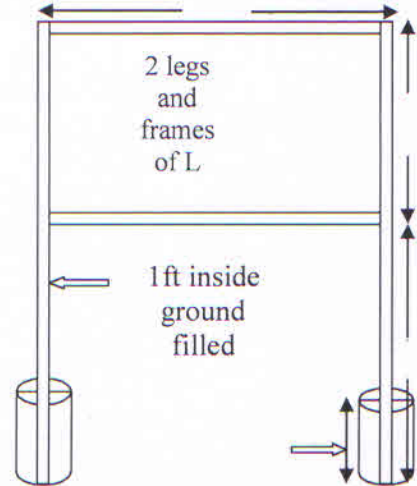

Rate Per Board=

132

Installation of SUMAN hoarding Type 1

Option 1: Single Panel ACP Display Board

Display Board (Vinyl board):
 5mm ACP Board pasted with upper high efficiency full cube Retro-reflective sheeting of white colour bonded over which alphabets and numerical are Printed using OEM matched component inks and UV laminated with OEM approved over laminates for longevity.

Size: 10' x 4'

Mounting & Installation of Display Panel:

The display panels shall be fitted (as per the drawings mentioned below) with two legs of 2" x 2" and 18 gauge square pipes. The pipes shall be made of Mild Steel, painted with primer and enamel Colour paint. The total height of the legs shall be 10' out of which 2' shall be inside the ground level with concrete and rest 8' shall be above ground level.

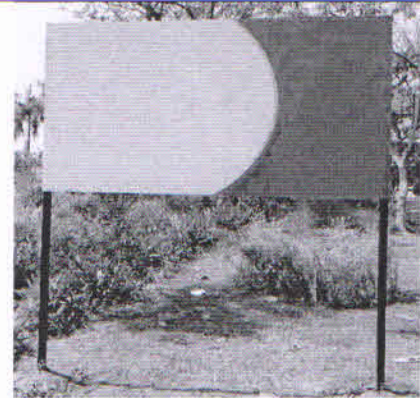

Rate Per Board

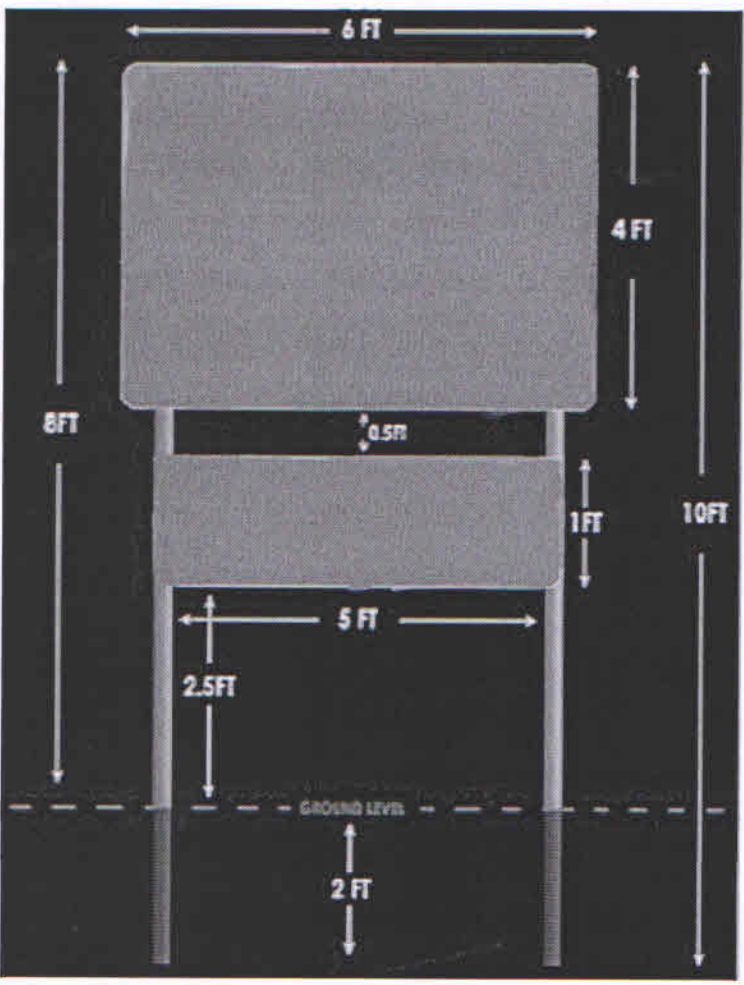
<p>133</p>	<p>Installation of SUMAN hoarding Type 2</p>	<p>Option2: Double Panel ACP Display Board</p> <p>ACP with vinyl pasted Display Board: 5mmACPBoardpastedwitheco-solvent vinyl printing & matt lamination for longevity.</p> <p>Size(Top Panel Display Board): 6'x 4'</p> <p>Size(Bottom Panel Display Board): 5'x1'</p> <p>Mounting & Installation of Display Panel: The two display panels (Top & Bottom) shall be fitted (as per the drawings mentioned below) with two legs of 2"x2" and 18 gauge square pipes. The pipes shall be made of Mild Steel, painted with primer and enamel colour paint. The total height of the legs shall be 10' out of which 2' shall be inside the ground levelwithconcreteandrest8'shallbeabove</p> 	<p>Rate Per Board</p>
------------	--	---	-----------------------



134	Dynamic Steel/ Aluminum frame wide base Standee	<p>Preferable Specifications:</p> <ul style="list-style-type: none"> ✓ Size:5ftX3ftor6ftX3ft ✓ Frame: Aluminum frame with wide base(reusable) ✓ Multi Colour fabric media printing with mounting <p>or</p> <p>Standees may be framed using 202 grade steel frames of 3" gauge square pipes with mounting of fabric banners.</p> <p>The matter of the standees should be changed as per the requirement during different occasion sand it should be displayed in a suitable place for better visibility to the public on a long term basis.</p>	PerSq.ft.
135	Printing of Health Calendar	<p>The calendars may be printed by hifed external agencies following due procurement procedures as per the specifications mentioned below; Specifications for wall hanging calendar:</p> <ol style="list-style-type: none"> a. Size-11.5inchX18inch(Half Demy) b. Paper-130GSM Art Paper c. Process - Multi Colour off set printing d. Binding - Wire-O binding including hanger e. Noofsheets:7sheets(14pages)both side printing f. Lamination: 8 pages glossy lamination(Optional) <p>During tender process rate quote maybe invited with lamination and without lamination. If laminated calendars rate quote are within the budgetary limits then order may be given for laminated calendars or else go for not laminated option.</p>	Rate Per Calendar
136	Flip book for MAS,ASHA & Other FLWs	<p>Suggested specifications:</p> <p>Size : 30cmX20cm</p> <p>Pages : 50 pages (25 sheets)(Tentative)</p> <p>Paper : 300 GSM Art Paper Printing: Multi colour Binding:-Wire-O binding</p> <p>- Inner pages bothside glossy lamination</p> <p>Table Stand: 28no. mill board with 130 GSM art paper cover pasting</p>	Rate Per Book
137	FAQ	<p>Size-22cmx28cm (A4)</p> <p>Process: Multi Colour</p> <p>Paper : 90 gsm Art Paper</p> <p>Cover Page:170 gsm Art Paper.</p>	Per Piece Rate

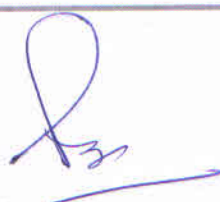

138	SUN BOARD WITH VINYLE	Materials to be used - 3 mm Thickness Sun Board. Printing Process – Eco Solvent Vinyl Print Multi colour & mounting with steel stud in 4 corners at institutions. (Including fitting charges)	Rate Per Sq. Ft
139	FLIP BOOK Type 1	Suggested specifications: Size : 30cmX20cm Pages : 30 pages (15 sheets) (Tentative) Paper : 300 GSM Art Paper Printing: Multi colour Binding:- Wire-O binding - Inner pages both side glossy lamination. * Table Stand: 28no. mill board with 130 GSM art paper Cover pasting.	Rate Per Book
140	FLIP BOOK Type 2	Suggested specifications: Size : 30cmX20cm Pages : 50 pages (25 sheets)(Tentative) Paper : 300 GSM Art Paper Printing: Multi colour Binding:- Wire-O binding - Inner pages bothside glossy lamination Table Stand: 28no. mill board with 130 GSM art paper cover pasting	Rate Per Book
141	FLIP BOOK Type 3	Suggested specifications: Size : 30cmX20cm Pages : 80 pages (40 sheets)(Tentative) Paper : 300 GSM Art Paper Printing: Multi colour Binding:- Wire-O binding - Inner pages both side glossy lamination Table Stand: 28no. mill board with 130 GSM art paper cover Pasting.	Rate Per Book
142	CASE RECORD/ INFORMATION SHEET FOR TOBACCO CESSATION CENTER	Total Pages: 10-30 Pages Paper Size: A4 Cover: Cover 2 Page Paper: 60 or 70GSM Multi Colour: All Pages	Rate per Book
143	Printing of OPERATIONAL GUIDELINE	Total Pages: 50 to 100 Pages Paper Size: A4	Rate per Book

		Cover: Cover 2 Page (170 GSM) Paper: 130 GSM Multi Colour: All Pages	
144	PRINTING OF CBAC	Printing of forms in A 4 Paper, Double Side Printing, 60-70 GSM	Rate Per Piece
145	PRINTING OF NPCDCS REGISTER	B/W Both side printing & Binding - 200 Pages, Paper size-A 3, Paper Quality – 60 to 70 GSM. Post Process:- Binding with cardboard in last page & binding with 220 GSM paper on the top cover & last page of the Register.	Rate per Register
146	HWC OPD REGISTER	B/W Both side printing & Binding - 200 pages, Paper size-A 3, Paper Quality – 60 to 70 GSM. Post Process:- Binding with cardboard in last page & binding with 220 GSM paper on the top cover & last page of the Register.	Rate per Register
147	COTPA CHALLAN & RECEIPT BOOK	Size :-20 cms x 13 cms. Original & Duplicate copy, Single colour, 70 gsm paper, Pages-50 per book	Rate per Book
148	NBSU Case Sheet Docket folder Set (Each Case Sheet docket folder Set shall contain the 5 items) i.e. 1) Docket Folder: 1 No 2) Discharge Card: 1No 3) Neonatal Case Record Sheet: 1No 4) Treatment Continu & clinical condition record sheet: 3Nos 5) Monitoring Nurses Order Sheet: 1No	<u>1A Docket Folder with pocket (1No.)</u> Unit: Nos. Size:9.6"x12" (Folding Size) Pages:4+inside 1 Pocket Paper:350GSM Art paper (Gloss Finish) Brightness:80 (Minimum) Printing: Multi Colour offset printing {(Front & Back of the folder) and on pocket } Folding &pasting: One Fold & One pocket (12x24 cm) pasting to contain 9-10nos.sheet. <u>1 B Discharge Card (1No.)</u> Unit: Nos. Size: 8.5"x11" (Folding Size) Pages: 4 Paper: 120GSM Maplitho, Brightness: 77 (Min.) Printing: Both Side Multi Colour offset printing . folding: One Fold <u>1 C Neonatal Case Record Sheet (1No.)</u> Unit: Nos. Size: 8.5"x11" (Folding Size) Pages: 4 Paper: 120GSM Maplitho,	Rate per Docket folder Set

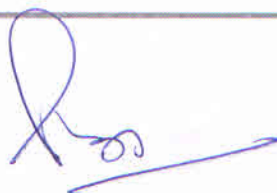

		<p>Brightness: 77 (Min.) Printing: Both Side Multi Colour offset printing . folding: One Fold <u>1 D Treatment Continuation & clinical condition record sheet</u> <u>(3No.)</u> Unit: Nos. Size: 8.5"x11" Pages: 2 pages back to back Paper: 90GSM Maplitho, Brightness: 77 (Min.) Printing: Bi Colour offset printing . <u>1 E Monitoring Nurses Order Sheet (1No.)</u> Unit: Nos. Size: 8.5"x11" Pages: 2 pages back to back Paper: 90GSM Maplitho, Brightness: 77 (Min.) Printing: Bi Colour offset printing .</p>	
149	<p>SNCU Case Sheet Docket folder Set (Each Case Sheet docket folder Set shall contain the 6 items) i.e. 1) Docket Folder: 1 No 2) Discharge Card: 1No 3) Neonatal Case Record Sheet: 1No 4) Investigation Sheet 1No 5) Treatment Continu & clinical condition record sheet: 3Nos 6) Monitoring & Nurses Order Sheet: 1No</p>	<p><u>1A Docket Folder with pocket (1No.)</u> Unit: Nos. Size:9.6"x12" (Folding Size) Pages:4+inside 1 Pocket Paper:350GSM Art paper (Gloss Finish) Brightness:80 (Minimum) Printing: Multi Colour offset printing {(Front & Back of the folder) and on pocket } Folding &pasting: One Fold & One pocket (12x24 cm) pasting to contain 9-10nos.sheet. <u>1 B Discharge Card (1No.)</u> Unit: Nos. Size: 8.5"x11" (Folding Size) Pages: 4 Paper: 120GSM Maplitho, Brightness: 77 (Min.) Printing: Both Side Multi Colour offset printing . folding: One Fold <u>1 C Neonatal Case Record Sheet (1No.)</u> Unit: Nos. Size: 8.5"x11" (Folding Size) Pages: 4 Paper: 120GSM Maplitho, Brightness: 77 (Min.) Printing: Both Side Multi Colour offset printing .</p>	Rate per Docket folder

		<p>folding: One Fold</p> <p><u>1 D Investigation Sheet (1No.)</u></p> <p>Unit: Nos.</p> <p>Size: 8.5"x11"</p> <p>Pages: 2 pages back to back</p> <p>Paper: 90GSM Maplitho,</p> <p>Brightness: 77 (Min.)</p> <p>Printing: Bi Colour offset printing .</p> <p><u>1 E Treatment Continuation & clinical condition record sheet (3No.)</u></p> <p>Unit: Nos.</p> <p>Size: 8.5"x11"</p> <p>Pages: 2 pages back to back</p> <p>Paper: 90GSM Maplitho,</p> <p>Brightness: 77 (Min.)</p> <p>Printing: Bi Colour offset printing .</p> <p><u>1 F Monitoring Nurses Order Sheet (1No.)</u></p> <p>Unit: Nos.</p> <p>Size: 8.5"x11"</p> <p>Pages: 2 pages back to back</p> <p>Paper: 90GSM Maplitho,</p> <p>Brightness: 77 (Min.)</p> <p>Printing: Bi Colour offset printing .</p>	
150	<p>Child Death Review Forms set (Contains 7 Nos of Form i.e. Form 1, 2, 3a, 3b, 3c, 4a, & 4b)</p>	<p style="text-align: center;"><u>Form-1</u></p> <p>Unit: Booklet</p> <p>Size: 1/4 Demy</p> <p>No.of Sheets: 50</p> <p>Paper: 80GSM Map Litho,</p> <p>Brightness: 77 (Min.)</p> <p>Printing: Both side Black offset Printing</p> <p>Binding: Top Pad binding with hard straw board (2mm) on back side</p> <p style="text-align: center;"><u>Form-2 (1st Brief Investigation Report for ANMs)</u></p> <p>Unit: Forms</p> <p>Size: 1/4 Demy (Closing Size)</p> <p>Pages: 4</p> <p>Paper: 80GSM Map Litho,</p> <p>Brightness: 77 (Min.)</p> <p>Printing: Both side Black offset Printing</p> <p>Binding: One Folding at the middle</p> <p style="text-align: center;"><u>Form-3a (Verbal Autopsy Form: Neonatal Deaths)</u></p>	Rate per set



Unit: Forms
Size: 1/4 Demy
Pages: 6
Paper: 80GSM Map Litho,
Brightness: 77 (Min.)
Printing: Both side Black offset Printing
Binding: Side stapling (2 nos. side stapling)

Form-3b (Verbal Autopsy Form: Post Neonatal Deaths)

Unit: Forms
Size: 1/4 Demy
Pages: 6
Paper: 80GSM Map Litho,
Brightness: 77 (Min.)
Printing: Both side Black offset Printing
Binding: Side stapling (2 nos. side stapling)

Form-3c (Social Autopsy Form)

Unit: Forms
Size: 1/4 Demy (Closing Size)
Pages: 4
Paper: 80GSM Map Litho,
Brightness: 77 (Min.)
Printing: Both side Black offset Printing
Binding: One Folding at the middle

Form-4a (Facility based Neonatal Death Review Form)

Unit: Forms
Size: 1/4 Demy
Pages: 6
Paper: 80GSM Map Litho,
Brightness: 77 (Min.)
Printing: Both side Black offset Printing
Binding: Side stapling (2 nos. side stapling)

Form-4b (Facility based Post Neonatal Death Review Form)

Unit: Forms
Size: 1/4 Demy
Pages: 6
Paper: 80GSM Map Litho,
Brightness: 77 (Min.)
Printing: Both side Black offset Printing
Binding: Side stapling (2 nos. side stapling)

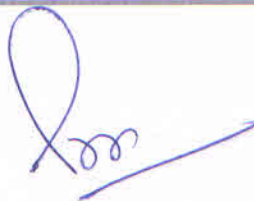

151	Gentamicin Treatment Card	Size: 17cm x 28cm Printing Type: Both sided Multi-colour offset printing Paper Quality: 250 GSM Art Paper (Matt Finish) Brightness: 80 (Min.)	Rate per Card
-----	----------------------------------	--	---------------

- N:B:**
- 1) The Rate quoted should be inclusive of all charges (i.e. DTP, Printing, Fixing, Designing, Materials, Transportation cost* & manpower etc.) but excluding GST as applicable
 - 2) Fixing of Branding Material & Wall writing are to be done at different health Institutions of Sundargarh District (may be at DHH/SDH/ block CHC's/PHC/SC/GKS level etc).
 - 3) The work should be completed or handed over within the time limit & as per specifications as above mentioned in the work order.

Place :
Date :

Signature & Seal of the authorised Signature.
Mobile No:

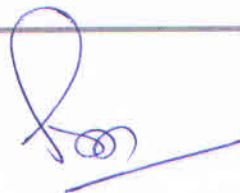

Financial Bid (Part of Cover B)

SI No	NAME OF THE ITEM	Specification as per Technical Bid Section III	Unit of measurement	Quoted Rate inclusive of all charges & Fright but Exclusive GST (Amt in Rs up to 2 decimal)
1	Poster for GKS/WKS Swasthya Kantha	As per Specification	Per Piece Rate	
2	Calendar	As per Specification	Per Piece Rate	
3	Poster (Type 1)	As per Specification	Per Piece Rate	
4	Poster (Type 2)	As per Specification	Per Piece Rate	
5	Poster (Type 2)	As per Specification	Per Piece Rate	
6	Poster (Type 3)	As per Specification	Per Piece Rate	
7	Poster (Type 4)	As per Specification	Per Piece Rate	
8	Poster (Type 5)	As per Specification	Per Piece Rate	
9	Poster (Type 6)	As per Specification	Per Piece Rate	
10	Leaflet (type 7)	As per Specification	Per Piece Rate	
11	Leaflet (type 2)	As per Specification	Per Piece Rate	
12	Leaflet (type 3)	As per Specification	Per Piece Rate	
13	Leaflet (type 4)	As per Specification	Per Piece Rate	
14	Leaflet (type 5)	As per Specification	Per Piece Rate	
15	Leaflet (type 6)	As per Specification	Per Piece Rate	
16	Leaflet (type 7)	As per Specification	Per Piece Rate	
17	Leaflet (type 8)	As per Specification	Per Piece Rate	
18	Folder (Type 1)	As per Specification	Per Piece Rate	
19	Folder (Type 2)	As per Specification	Per Piece Rate	
20	Folder (Type 3)	As per Specification	Per Piece Rate	
21	Folder (Type 4)	As per Specification	Per Piece Rate	
22	Folder (Type 5)	As per Specification	Per Piece Rate	
23	Folder (Type 6)	As per Specification	Per Piece Rate	
24	Handouts (Type 1)	As per Specification	Per Piece Rate	

25	Handouts (Type 2)	As per Specification	Per Piece Rate	
26	Handouts (Type 3)	As per Specification	Per Piece Rate	
27	Handouts (Type 4)	As per Specification	Per Piece Rate	
28	Handouts (Type 5)	As per Specification	Per Piece Rate	
29	Handouts (Type 6)	As per Specification	Per Piece Rate	
30	Handouts (Type 7)	As per Specification	Per Piece Rate	
31	Flipcharts	As per Specification	Per Piece Rate	
32	Docket	As per Specification	Per Piece Rate	
33	Hand Bill	As per Specification	Per Piece Rate	
34	Patient Treatment Card Book let	As per Specification	Rate per Booklet	
35	Patient Case Card	As per Specification	Rate per card	
36	Printing Forms (Type 1)	As per Specification	Rate Per Piece	
37	Printing Forms (Type 2)	As per Specification	Rate Per Piece	
38	Printing Forms (Type 3)	As per Specification	Rate Per Piece	
39	Printing Forms (Type 4)	As per Specification	Rate Per Piece	
40	Printing Forms (Type 5)	As per Specification	Rate Per Piece	
41	Printing Forms (Type 6)	As per Specification	Rate Per Piece	
42	Printing Forms (Type 7)	As per Specification	Rate Per Piece	
43	Printing Forms (Type 8)	As per Specification	Rate Per Piece	
44	Printing Forms (Type 9)	As per Specification	Rate Per Piece	
45	Printing Forms (Type 10)	As per Specification	Rate Per Piece	
46	Printing Forms (Type 11)	As per Specification	Rate Per Piece	
47	Printing Forms (Type 12)	As per Specification	Rate Per Piece	
48	HBNC Format	As per Specification	Rate per Booklet	
49	Monthly Meeting Register	As per Specification	Rate Per Register	
50	Grade Card	As per Specification	Rate per card	
51	Printing of various Incentive Voucher Book: 200 GSM thin board Cover page with binding	As per Specification	Rate per page	
52	Printing of various Incentive Voucher Book: 200 GSM thin board Cover page with binding	As per Specification	Rate per page	

53	Printing of Various Formats: 200 GSM thin board Cover page with binding	As per Specification	Rate per booklet	
54	Printing of Various Formats: 200 GSM thin board Cover page with binding	As per Specification	Rate per booklet	
55	Printing of various Training Modules: 220 GSM laminated Cover page (multi-Colour) with gum binding.	As per Specification	Rate per page	
56	Printing of various Training Modules: 220 GSM laminated Cover page (multi-Colour) with gum binding.	As per Specification	Rate per page	
57	Printing of various Training Modules: 220 GSM laminated Cover page (multi-Colour) with gum binding.	As per Specification	Rate per page	
58	Printing of various Training Modules: 220 GSM laminated Cover page (multi-Colour) with gum binding.	As per Specification	Rate per page	
59	Printing of St. Records & case card	As per Specification	Rate Per Booklet	
60	Booklet type 1	As per Specification	Rate Per Booklet	
61	Booklet type 2	As per Specification	Rate Per Booklet	
62	Register 1	As per Specification	Rate per Register	
63	Register 2	As per Specification	Rate per Register	
64	Rolling Register 1	As per Specification	Rate per Register	
65	Rolling Register 2	As per Specification	Rate per Register	
66	Register (Type 1)	As per Specification	Rate per Register	
67	Register (Type 2)	As per Specification	Rate per Register	
68	Register (Type 3)	As per Specification	Rate per Register	
69	Register (Type 4)	As per Specification	Rate per Register	
70	Register (Type 5)	As per Specification	Rate per Register	
71	Register (Type 6)	As per Specification	Rate per Register	
72	Register (Type 7)	As per Specification	Rate per Register	
73	Register (Type 8)	As per Specification	Rate per Register	
74	Incentive Voucher book	As per Specification	Rate per voucher book	
75	Envelope type 1	As per Specification	Rate per Envelope	
76	Envelope type 2	As per Specification	Rate per Envelope	
77	Sticker Type 1	As per Specification	Rate per Sticker	
78	Sticker Type 2	As per Specification	Rate per Sticker	

79	E-Auto Sticker type 1	As per Specification	Rate Per Sq. Ft	
80	E-Auto Sticker type 2	As per Specification	Rate Per Sq. Ft	
81	Standee Type 1	As per Specification	Rate per standee	
82	Standee Type 2	As per Specification	Rate per sqft	
83	Standee Rolling Type	As per Specification	Rate per sqft	
84	Invitation Card	As per Specification	Rate per Card	
85	Certificate	As per Specification	Rate per certificate	
86	Pushing Card	As per Specification	Per Card	
87	Identity Card/ Grade Card	As per Specification	Per Card	
88	Printing of Flex Banner	As per Specification	Rate Per Sq. Ft	
89	Flex print	As per Specification	Rate Per Sq. Ft	
		As per Specification	Rate Per Sq. Ft	
90	Change of Flex in Hoardings	As per Specification	Rate per Sq. Ft. for Hoarding flex change	
91	Exhibit/Standee	As per Specification	Rate Per Sq. Ft	
92	Vehicle Decoration	As per Specification	Rate Per vehicle	
93	Wall Painting	As per Specification	Rate Per Sq. Ft	
94	Printing & Mounting of IEC materials (Sun Board) Type 1	As per Specification	Rate Per Sq. Ft	
95	Printing & Mounting of IEC materials (Sun Board) Type 2	As per Specification	Rate Per Sq. Ft	
96	Retro Signage for RI & UHND/VHND points	As per Specification	Rate Per Sq. Ft	
97	Branding/Mounting of IEC materials	As per Specification	Rate Per Sq. Ft.	
98	Cloth Banner Type 1	As per Specification	Rate per unit	
99	Cloth Banner Type 2	As per Specification	Rate per unit	
100	Branding of Vehicles	As per Specification	Rate Per Sq. Ft.	
101	IPU Sign Board Type 1	As per Specification	Rate Per Sq. Ft.	
102	IPU Sign Board Type 2	As per Specification	Rate Per Sq. Ft.	
103	IPU Sign Board Type 3	As per Specification	Rate Per Sq. Ft.	
104	IPU Sign Board Type 4	As per Specification	Rate Per Sq. Ft.	
105	IPU Sign Board Type 5	As per Specification	Rate Per Sq. Ft.	
106	Signage	As per Specification	Rate Per Sq. Ft	

107	Digital Display Board	As per Specification	Rate Per Sq. Ft	
108	Tin Plate 1	As per Specification	Rate per Piece	
109	Tin Plate 2	As per Specification	Rate per Piece	
110	Glow Sign Board	As per Specification	Rate per Sqft	
111	Vinyl print(Poster)	As per Specification	Rate per Sqft	
112	Erection of new Hoarding	As per Specification	Rate Per Sq. Ft.	
113	Welcome Board of MAS	As per Specification	Rate Per Sq. Ft.	
114	Mini Hoarding	As per Specification	Rate Per Sq. Ft.	
115	Installation of Retro-Hoarding	As per Specification	Rate Per Sq. Ft.	
116	Printing of Fabric Banner	As per Specification	Rate Per Sq. Ft.	
117	Canopy Type 1	As per Specification	Rate Per Sq. Ft.	
118	Canopy Type 2	As per Specification	Rate Per Sq. Ft.	
119	Canopy Type 3	As per Specification	Rate Per Sq. Ft.	
120	Canopy Type 4	As per Specification	RatePer Sq. Ft.	
121	IEC Calendar	As per Specification	Rate per Calendar	
122	Exhibits	As per Specification	Rate Per Sq. Ft.	
123	Display Board	As per Specification	Rate Per Sq. Ft.	
124	Installation of Retro-Hoarding	As per Specification	Rate Per Sq. Ft.	
125	Permanent (Iron Frame) Hoardings near religious places, along highways, market places and other strategic	As per Specification	Rate Per Sq. Ft.	
126	Change of matter(Fabric) in existing Large hoardings	As per Specification	Rate Per Sq. Ft.	
127	Mini Hoardings Type 1	As per Specification	Rate Per Sq. Ft.	
128	Mini Hoardings Type 2	As per Specification	Rate Per Sq. Ft.	
129	Retro Signage for UHND & RI Points	As per Specification	Rate Per Sq. Ft.	
130	Wall paintings for health education WKS	As per Specification	Rate Per Sq. Ft.	
131	Welcome Board of MAS 1PerMAS	As per Specification	Per Board	
132	Installation of SUMAN hoarding Type 1	As per Specification	Per hoarding	
133	Installation of SUMAN hoarding Type 2	As per Specification	Per hoarding	

134	Dynamic Steel/ Aluminum frame wide base Standee	As per Specification	RatePer Sq. Ft.	
135	Printing of Health Calendar	As per Specification	Rate Per Calendar	
136	Flipbook for MAS,ASHA& Other FLWs	As per Specification	Rate Per Book	
137	FAQ	As per Specification	Per Piece Rate	
138	SUN BOARD WITH VINYLE	As per Specification	Rate Per Sq. Ft	
139	FLIP BOOK Type 1	As per Specification	Rate Per Book	
140	FLIP BOOK Type 2	As per Specification	Rate Per Book	
141	FLIP BOOK Type 3	As per Specification	Rate Per Book	
142	CASE RECORD/ INFORMATION SHEET FOR TOBACCO CESSATION CENTER	As per Specification	Rate per Book	
143	Printing of OPERATIONAL GUIDELINE	As per Specification	Rate per Book	
144	PRINTING OF CBAC	As per Specification	Rate Per Piece	
145	PRINTING OF NPCDCS REGISTER	As per Specification	Rate per Register	
146	HWC OPD REGISTER	As per Specification	Rate per Register	
147	COTPA CHALLAN & RECEIPT BOOK	As per Specification	Rate per Book	
148	NBSU Case Sheet Docket folder Set	As per Specification	Rate per Docket folder Set	
149	SNCU Case Sheet Docket folder Set	As per Specification	Rate per Docket folder Set	
150	Child Death Review Forms set	As per Specification	Rate per set	
151	Gentamicin Treatment Card	As per Specification	Rate per Card	

Note: The Rate quoted should be (maximum up to two decimal) inclusive of all charges (i.e. DTP, Printing, Fixing, Designing, Materials, Transportation cost & manpower etc.) but exclusive of GST as applicable and valid for minimum one year from the date of finalization of tender. Each Page should be signed and no overwriting in rate allowed.



Signature with Seal